

Please check the examination details below before entering your candidate information

Candidate surname

Other names

**Pearson Edexcel**  
**International**  
**Advanced Level**

Centre Number

--	--	--	--	--

Candidate Number

--	--	--	--	--

**Monday 20 January 2020**

Morning (Time: 1 hour 30 minutes)

Paper Reference **WPH12/01**

**Physics**

**International Advanced Subsidiary / Advanced Level**  
**Unit 2: Waves and Electricity**

**You must have:**

Scientific calculator, Ruler

Total Marks

### Instructions

- Use **black** ink or ball-point pen.
- **Fill in the boxes** at the top of this page with your name, centre number and candidate number.
- Answer **all** questions.
- Answer the questions in the spaces provided – *there may be more space than you need.*
- **Show all your working out in calculations and include units where appropriate.**

### Information

- The total mark for this paper is 80.
- The marks for **each** question are shown in brackets – *use this as a guide as to how much time to spend on each question.*
- In questions marked with an **asterisk (\*)**, marks will be awarded for your ability to structure your answer logically showing how the points that you make are related or follow on from each other where appropriate.
- The list of data, formulae and relationships is printed at the end of this booklet.

### Advice

- Read each question carefully before you start to answer it.
- Try to answer every question.
- Check your answers if you have time at the end.

Turn over ►

P60489A

©2020 Pearson Education Ltd.

1/1/1/1/



Pearson

## SECTION A

Answer ALL questions.

For questions 1–10 select one answer from A to D and put a cross in the box ☒.  
If you change your mind, put a line through the box ~~☒~~ and then  
mark your new answer with a cross ☒.

- 1 Two waves, of wavelength  $\lambda$ , from a single source diverge and then meet again.  
Which of the following situations would cause constructive interference?

- A a path difference of  $\frac{\lambda}{2}$
- B a path difference of  $\lambda$
- C a phase difference of  $\frac{\pi}{2}$
- D a phase difference of  $\pi$

(Total for Question 1 = 1 mark)

- 2 Which of the following describes the oscillations in polarised waves?

- A in a single plane which is perpendicular to the direction of wave travel
- B in many planes, which include the direction of wave travel
- C in many directions and parallel to the direction of wave travel
- D in one direction and perpendicular to the direction of wave travel

(Total for Question 2 = 1 mark)

- 3 Which row in the table shows the total resistance if two  $5\ \Omega$  resistors are connected  
in series and in parallel?

	Series	Parallel
<input type="checkbox"/> A	$2.5\ \Omega$	$10\ \Omega$
<input type="checkbox"/> B	$2.5\ \Omega$	$2.5\ \Omega$
<input type="checkbox"/> C	$10\ \Omega$	$10\ \Omega$
<input type="checkbox"/> D	$10\ \Omega$	$2.5\ \Omega$

(Total for Question 3 = 1 mark)

DO NOT WRITE IN THIS AREA

DO NOT WRITE IN THIS AREA

DO NOT WRITE IN THIS AREA



DO NOT WRITE IN THIS AREA

- 4 The current-potential difference graph for an ideal diode is shown. The graph has been labelled at three separate points by the letters X, Y and Z.

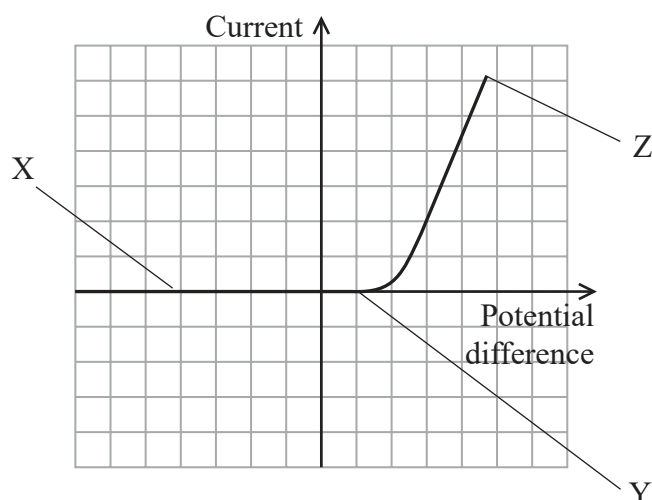

At which point(s) is the resistance of this diode infinite.

- A X and Y
- B Y and Z
- C X only
- D Z only

(Total for Question 4 = 1 mark)

- 5 A copper wire has a cross-sectional area of  $5.0 \times 10^{-7} \text{ m}^2$ . There is a current in the wire of 0.93 A. Copper has  $8.4 \times 10^{28}$  conduction electrons per metre cubed.

Which of the following gives the magnitude of the drift velocity  $v$  in  $\text{m s}^{-1}$  for the conduction electrons in this wire?

- A  $v = \frac{0.93}{(8.4 \times 10^{28})(5.0 \times 10^{-7})}$
- B  $v = \frac{(8.4 \times 10^{28})(1.6 \times 10^{-19})(5.0 \times 10^{-7})}{0.93}$
- C  $v = \frac{(8.4 \times 10^{28})(5.0 \times 10^{-7})}{0.93}$
- D  $v = \frac{0.93}{(8.4 \times 10^{28})(1.6 \times 10^{-19})(5.0 \times 10^{-7})}$

(Total for Question 5 = 1 mark)

DO NOT WRITE IN THIS AREA



6 When the photoelectric effect occurs, light incident on the surface of a metal releases electrons.

Which of the following is an experimental observation of the photoelectric effect?

- A Electrons are only released after light has been incident for a long time.
- B Increasing the frequency of the light increases the maximum kinetic energy of the released electrons.
- C Increasing the intensity of the light increases the maximum kinetic energy of the released electrons.
- D Only light with a wavelength above a threshold value releases electrons.

(Total for Question 6 = 1 mark)

7 A negative temperature coefficient thermistor is connected in a circuit as shown.

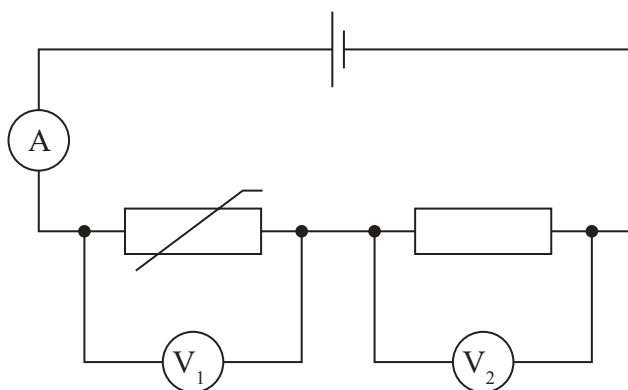

The temperature of the thermistor is increased.

Which row of the table shows how the readings on meters  $V_1$  and  $V_2$  and A change?

	Reading on $V_1$	Reading on $V_2$	Reading on A
<input type="checkbox"/> A	decreases	increases	increases
<input type="checkbox"/> B	decreases	stays the same	increases
<input type="checkbox"/> C	increases	decreases	decreases
<input type="checkbox"/> D	increases	stays the same	decreases

(Total for Question 7 = 1 mark)



8 Waves may be longitudinal or transverse.

Which of the following statements is correct?

- A All transverse waves travel at the same speed.
- B All transverse waves have vibrations that are parallel to the direction of wave travel.
- C Both transverse and longitudinal waves can be refracted.
- D No transverse waves can travel through liquids.

(Total for Question 8 = 1 mark)

9 In an experiment, laser light is shone through a diffraction grating so that a series of bright dots appears on a screen. The equation  $n\lambda = d\sin\theta$  can be used to determine the wavelength of the laser light.

Which of the following is a **correct** description of how the experiment should be performed?

- A The angle  $\theta$  is measured using a protractor.
- B The diffraction grating is set up so that it is parallel to the laser light beam.
- C The diffraction grating is set up so that it is parallel to the screen.
- D The distance between the bright dots is measured with a micrometer.

(Total for Question 9 = 1 mark)

10 The evidence for the wave nature of electrons came from experiments involving

- A diffraction.
- B polarisation.
- C reflection.
- D refraction.

(Total for Question 10 = 1 mark)

**TOTAL FOR SECTION A = 10 MARKS**



## SECTION B

Answer ALL questions in the spaces provided.

- 11 An experiment is carried out to investigate the speed of transverse waves on a stretched string of length  $L$ . A vibration generator causes the string to oscillate so that a stationary wave is produced. The frequency of the vibration generator is adjusted until the wave pattern shown in the diagram is produced.

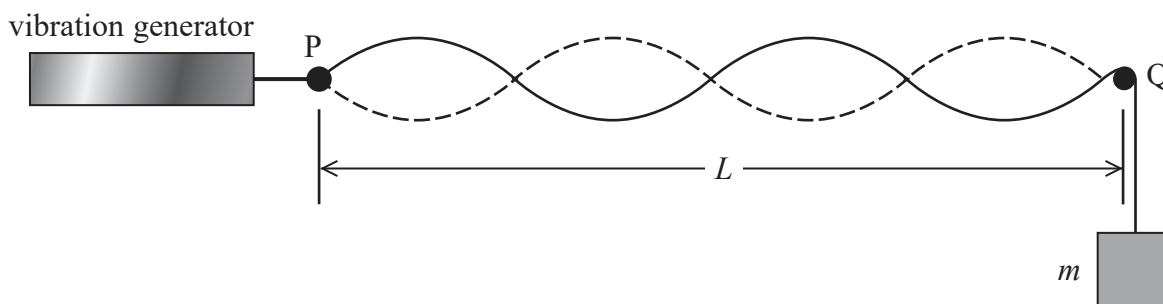

Sourced from: [https://people.highline.edu/iglozman/classes/physnotes/media/waves\\_9.jpg](https://people.highline.edu/iglozman/classes/physnotes/media/waves_9.jpg)

- (a) Determine the wavelength of the waves on the string when vibrating as shown.

length  $L = 1.70 \text{ m}$

(2)

Wavelength = .....

- (b) Calculate the speed of waves on the string.

mass  $m = 0.20 \text{ kg}$

mass per unit length of string =  $4.5 \times 10^{-3} \text{ kg m}^{-1}$

(3)

Speed = .....

DO NOT WRITE IN THIS AREA

DO NOT WRITE IN THIS AREA

DO NOT WRITE IN THIS AREA



DO NOT WRITE IN THIS AREA

DO NOT WRITE IN THIS AREA

DO NOT WRITE IN THIS AREA

(c) The frequency of the vibration generator is reduced until the wave pattern shown below is produced.



Explain the effect that this would have on the speed of the waves on the string.

(2)

.....

.....

.....

.....

.....

**(Total for Question 11 = 7 marks)**



12 Solar panels generate electricity when sunlight is incident on the surface of the panel.

- (a) The total generation of electricity worldwide in the year 2014 was approximately 23 800 TWh (1 TWh =  $3.6 \times 10^{15}$  J).

Some scientists claim that if the Sahara Desert were covered with solar panels, sufficient electricity could be generated to supply the whole world.

- (i) Calculate the maximum energy received by the solar panels in one hour.

maximum intensity of solar radiation at the Earth's surface =  $1100 \text{ Wm}^{-2}$

area of Sahara Desert =  $9.2 \times 10^{12} \text{ m}^2$

(2)

.....

.....

.....

.....

Maximum energy received in one hour = .....

- (ii) Determine whether covering the Sahara Desert with solar panels would be able to generate enough electricity for the whole world.

(2)

.....

.....

.....

.....

- (b) Sand storms are common in the Sahara Desert.

Explain why sand storms reduce the power generated by the solar panels.

(2)

.....

.....

.....

.....

(Total for Question 12 = 6 marks)







14 Photocells make use of the photoelectric effect. The following circuit can be used to determine the work function of a metal used in a photocell.

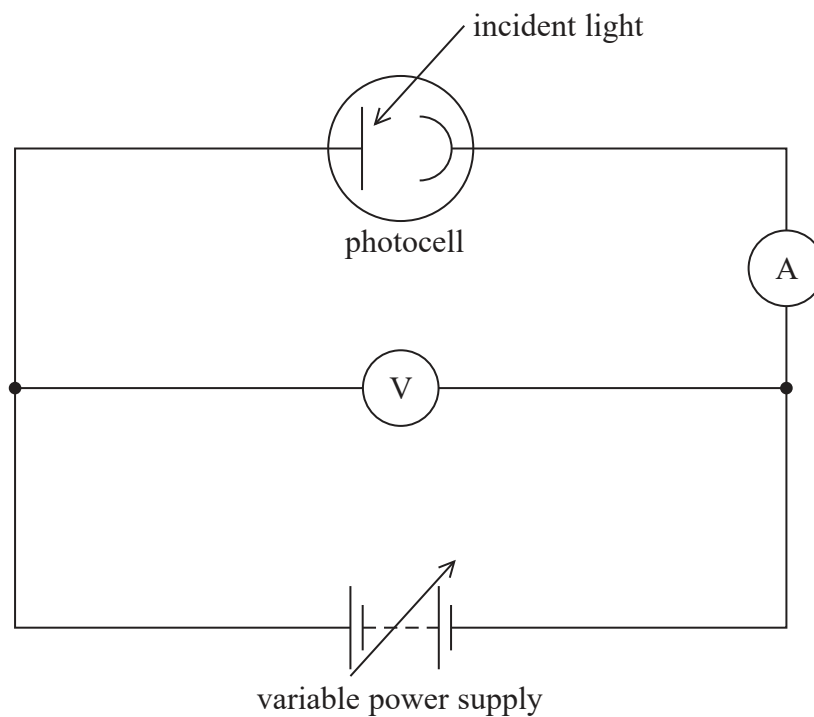

(a) State what is meant by the work function of a metal.

(1)

.....

.....

.....

.....

(b) This photocell works with ultraviolet light but does not work with visible light.

Explain why.

(2)

.....

.....

.....

.....

DO NOT WRITE IN THIS AREA

DO NOT WRITE IN THIS AREA

DO NOT WRITE IN THIS AREA



(c) An experiment was carried out using this circuit. The potential difference applied to the photocell opposes the movement of the electrons through the photocell, reducing the current.

- (i) The variable power supply was initially set at 0 V and the reading on the ammeter was  $2.4 \mu\text{A}$ .

The intensity of the ultraviolet light was then increased without changing the frequency.

Explain what happened to the reading on the ammeter.

(3)

- (ii) The variable power supply was adjusted until the reading on the ammeter became  $0 \mu\text{A}$ . The reading on the voltmeter was 3.59 V.

Calculate the work function, in joules, of the metal used in the photocell.

frequency of ultraviolet used =  $2.00 \times 10^{15} \text{ Hz}$

(4)

Work function = ..... J

(Total for Question 14 = 10 marks)



- 15 A water wave approaches a boundary between deep water and shallow water and is refracted. The diagram shows how the direction of travel of the wave changes.

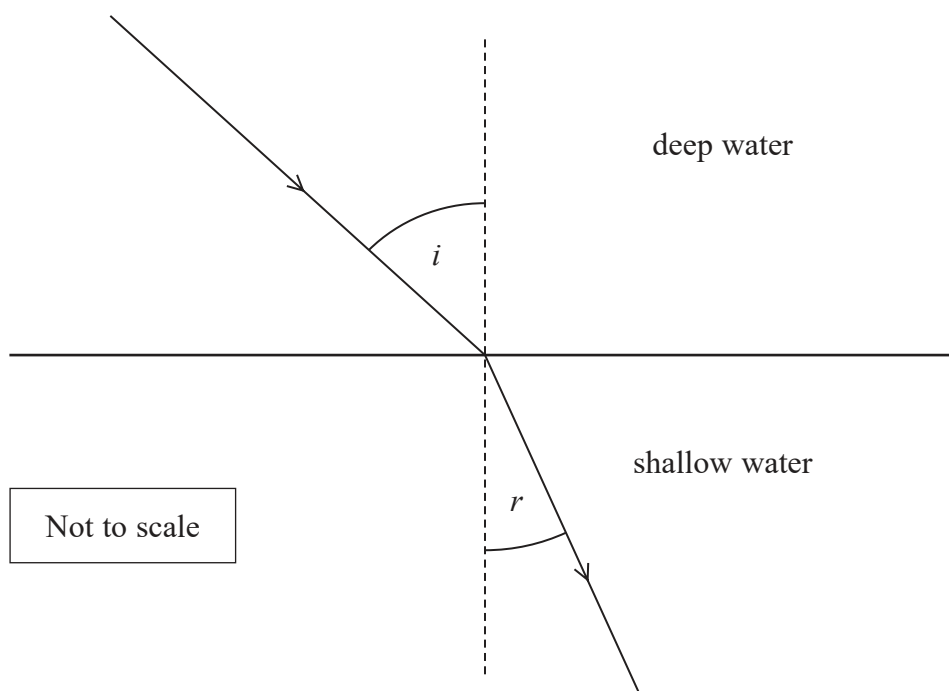

- (a) Explain why the wave is refracted as shown, as it travels from deep water into shallow water. You may add to the diagram.

(2)

- (b) When waves travel across the surface of water, their speed  $v$  is dependent on the depth  $d$  of the water and the wavelength  $\lambda$  of the waves.

For waves travelling in deep water, where  $d > \frac{\lambda}{2}$ ,  $v = \sqrt{\frac{g\lambda}{2\pi}}$

For waves travelling in shallow water,  $v = \sqrt{gd}$



(i) Calculate the angle of refraction  $r$ .

wavelength of waves in deep water = 15 m

depth of deep water = 10 m

depth of shallow water = 0.50 m

angle of incidence =  $40^\circ$

(5)

$r =$  .....

(ii) In 1933, the crew of the US Navy ship USS Rampo took measurements from one of the largest waves ever recorded. The wavelength of the wave was 342 m and the time period was 14.8 s.

Show that the depth of the water where the crew measured the wave was greater than 170 m.

(3)

(Total for Question 15 = 10 marks)

DO NOT WRITE IN THIS AREA

DO NOT WRITE IN THIS AREA

DO NOT WRITE IN THIS AREA



P 6 0 4 8 9 A 0 1 3 2 4

16 When laser light is directed through a small circular gap, a diffraction pattern can be observed on a screen as shown.

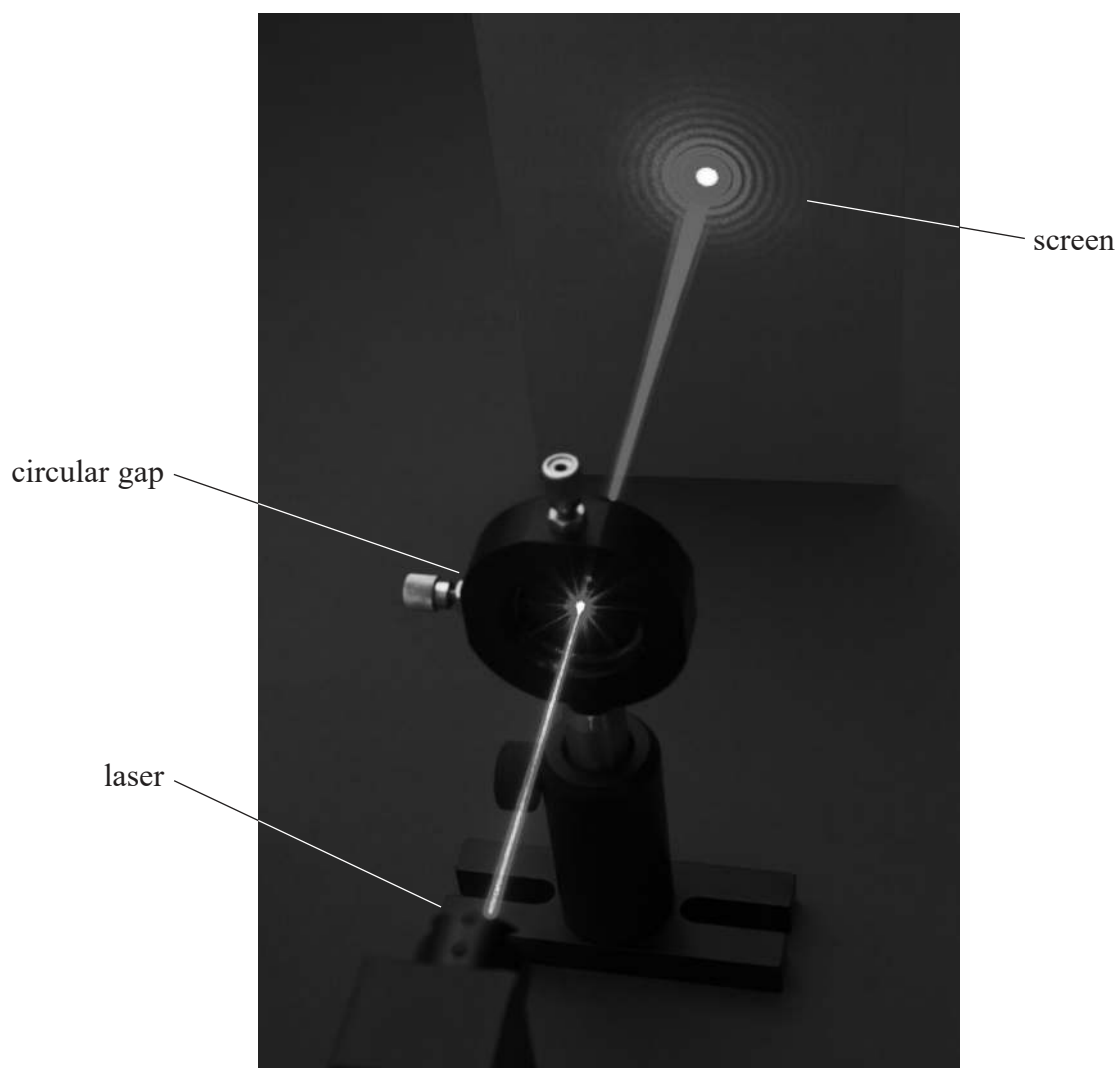

(Source: © GIPHOTOSTOCK/SCIENCE PHOTO LIBRARY)

(a) Explain, using Huygens' construction, how diffraction occurs as waves pass through a gap. (2)

.....

.....

.....

.....

DO NOT WRITE IN THIS AREA

DO NOT WRITE IN THIS AREA

DO NOT WRITE IN THIS AREA



- (b) The diffraction pattern consists of a central bright spot surrounded by concentric circles of light of decreasing intensity. A close-up of the pattern is shown below.

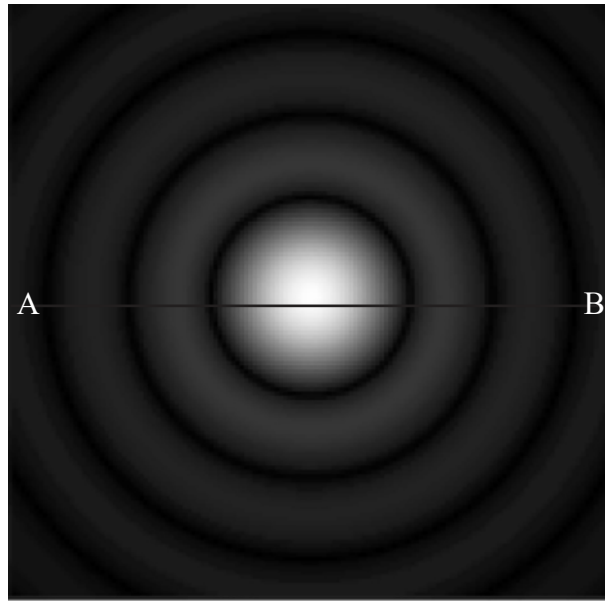

© KaiMartin

Sketch a graph showing how the intensity of the light in the diffraction pattern on the screen varies along the line AB.

(3)

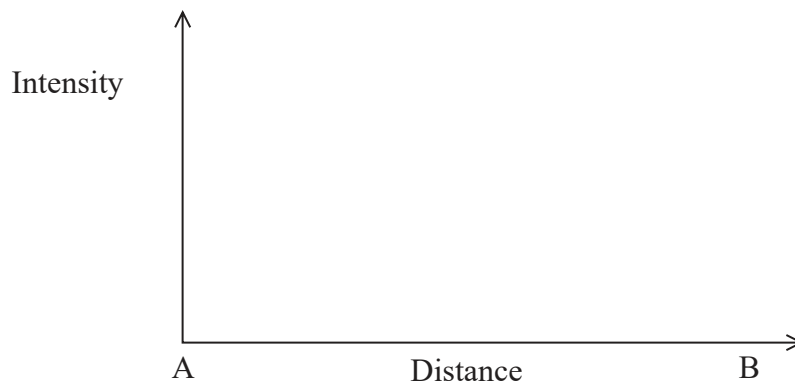

(Total for Question 16 = 5 marks)



17 A car battery is constructed using six cells connected in series, with a combined electromotive force (e.m.f.) of 12.00 V.

(a) State what is meant by e.m.f.

(1)

(b) A student set up the circuit shown, using the car battery.

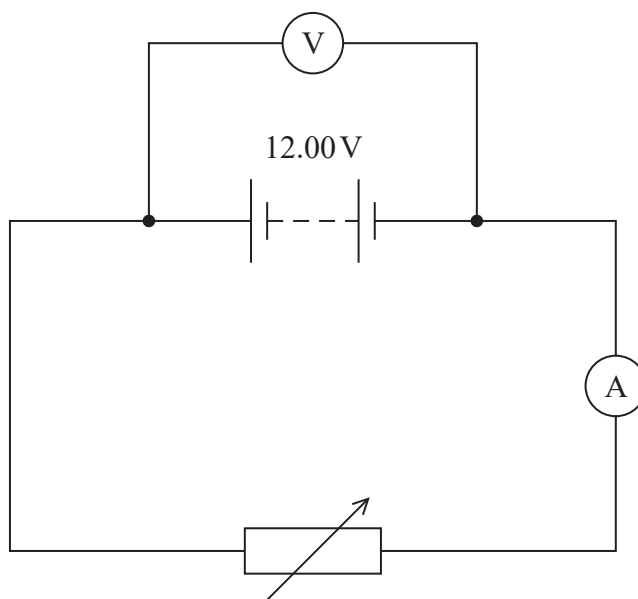

The student adjusted the variable resistor until the reading on the voltmeter was 11.81 V.  
The reading on the ammeter was 9.83 A.

(i) Calculate the internal resistance of the car battery.

(2)

Internal resistance = .....





- (ii) The student adjusted the variable resistor several times and recorded corresponding values from the ammeter and voltmeter.

Describe how the values can be used to determine the internal resistance of the battery using a graphical method.

(3)

.....

.....

.....

.....

.....

.....

- (c) With use, the internal resistance of a battery will increase. Eventually the power available from a battery will become too small to be useful.

The student calculated the power available from a battery of e.m.f 9.0 V and internal resistance  $0.10\ \Omega$  when connected across a  $5.0\ \Omega$  resistor.

He concluded that when the internal resistance had risen to  $0.50\ \Omega$ , the power dissipated in the  $5.0\ \Omega$  resistor would reduce to 70% of its original value.

Determine whether the student's conclusion is correct.

(4)

.....

.....

.....

.....

.....

.....

.....

.....

.....

.....

(Total for Question 17 = 10 marks)

DO NOT WRITE IN THIS AREA

DO NOT WRITE IN THIS AREA

DO NOT WRITE IN THIS AREA



- 18 The photograph shows a typical lightning strike which occurs as a result of an electrical discharge through the atmosphere in a narrow channel between a cloud and the ground.



(Source: © Joshua Lewis/EyeEm/Getty Images)

The high current in a lightning strike heats the air sufficiently to cause rapid expansion; the resulting shock wave is heard as thunder.

- (a) A teacher says that a lightning strike taking place 1 km away from the observer will result in a time of 3 s between seeing the lightning and hearing the thunder.

Determine whether the teacher is correct.

speed of sound in air =  $340 \text{ m s}^{-1}$

(3)

.....

.....

.....

.....

.....

.....



(b) The following data was collected for one particular lightning strike:

distance between cloud and ground = 400 m

current = 25 000 A

duration of lightning strike = 30  $\mu$ s

potential difference between cloud and ground =  $1.2 \times 10^9$  V

diameter of lightning channel = 5.0 cm

(i) Calculate the total charge transferred during the lightning strike.

(2)

Total charge transferred = .....

(ii) Calculate the power dissipated by the lightning strike.

(2)

Power dissipated = .....

(iii) Show that the resistivity of the air in the lightning channel is about  $0.2 \Omega\text{m}$ .

(3)



(iv) The accepted value for the resistivity of air is  $10^{16} \Omega\text{m}$ .

Suggest why the value calculated from the data is so much less than the accepted value. (1)

.....

.....

(c) Air consists mainly of nitrogen and oxygen molecules. Analysis of the light produced during a lightning strike shows a weak line spectrum.

(i) Explain the process by which nitrogen atoms produce a line spectrum. (4)

.....

.....

.....

.....

.....

.....

.....

.....

.....

.....

(ii) State why the line spectrum produced by oxygen atoms in the air would be different from the line spectrum produced by nitrogen atoms. (1)

.....

.....

**(Total for Question 18 = 16 marks)**

---

**TOTAL FOR SECTION B = 70 MARKS**  
**TOTAL FOR PAPER = 80 MARKS**

DO NOT WRITE IN THIS AREA

DO NOT WRITE IN THIS AREA

DO NOT WRITE IN THIS AREA



DO NOT WRITE IN THIS AREA

DO NOT WRITE IN THIS AREA

DO NOT WRITE IN THIS AREA

**BLANK PAGE**



### List of data, formulae and relationships

Acceleration of free fall	$g = 9.81 \text{ m s}^{-2}$	(close to Earth's surface)
Electron charge	$e = -1.60 \times 10^{-19} \text{ C}$	
Electron mass	$m_e = 9.11 \times 10^{-31} \text{ kg}$	
Electronvolt	$1 \text{ eV} = 1.60 \times 10^{-19} \text{ J}$	
Gravitational field strength	$g = 9.81 \text{ N kg}^{-1}$	(close to Earth's surface)
Planck constant	$h = 6.63 \times 10^{-34} \text{ Js}$	
Speed of light in a vacuum	$c = 3.00 \times 10^8 \text{ m s}^{-1}$	

#### Unit 1

##### Mechanics

Kinematic equations of motion

$$s = \frac{(u + v)t}{2}$$

$$v = u + at$$

$$s = ut + \frac{1}{2}at^2$$

$$v^2 = u^2 + 2as$$

Forces

$$\Sigma F = ma$$

$$g = \frac{F}{m}$$

$$W = mg$$

Momentum

$$p = mv$$

Moment of force

$$\text{moment} = Fx$$

Work and energy

$$\Delta W = F\Delta s$$

$$E_k = \frac{1}{2}mv^2$$

$$\Delta E_{\text{grav}} = mg\Delta h$$

Power

$$P = \frac{E}{t}$$

$$P = \frac{W}{t}$$

Efficiency

$$\text{efficiency} = \frac{\text{useful energy output}}{\text{total energy input}}$$

$$\text{efficiency} = \frac{\text{useful power output}}{\text{total power input}}$$

DO NOT WRITE IN THIS AREA

DO NOT WRITE IN THIS AREA

DO NOT WRITE IN THIS AREA



*Materials*

Density  $\rho = \frac{m}{V}$

Stokes' law  $F = 6\pi\eta rv$

Hooke's law  $\Delta F = k\Delta x$

Elastic strain energy  $\Delta E_{\text{el}} = \frac{1}{2}F\Delta x$

Young modulus  $E = \frac{\sigma}{\varepsilon}$  where

Stress  $\sigma = \frac{F}{A}$

Strain  $\varepsilon = \frac{\Delta x}{x}$



**Unit 2***Waves*

Wave speed  $v = f\lambda$

Speed of a transverse wave on a string  $v = \sqrt{\frac{T}{\mu}}$

Intensity of radiation  $I = \frac{P}{A}$

Refractive index  $n_1 \sin \theta_1 = n_2 \sin \theta_2$

$$n = \frac{c}{v}$$

Critical angle  $\sin C = \frac{1}{n}$

Diffraction grating  $n\lambda = d \sin \theta$

*Electricity*

Potential difference  $V = \frac{W}{Q}$

Resistance  $R = \frac{V}{I}$

Electrical power, energy  $P = VI$

$$P = I^2R$$

$$P = \frac{V^2}{R}$$

$$W = VI t$$

Resistivity  $R = \frac{\rho l}{A}$

Current  $I = \frac{\Delta Q}{\Delta t}$

$$I = nqvA$$

Resistors in series  $R = R_1 + R_2 + R_3$

Resistors in parallel  $\frac{1}{R} = \frac{1}{R_1} + \frac{1}{R_2} + \frac{1}{R_3}$

*Quantum physics*

Photon model  $E = hf$

Einstein's photoelectric equation  $hf = \phi + \frac{1}{2}mv_{\max}^2$

de Broglie wavelength  $\lambda = \frac{h}{p}$

Every effort has been made to contact copyright holders to obtain their permission for the use of copyright material. Pearson Education Ltd. will, if notified, be happy to rectify any errors or omissions and include any such rectifications in future editions

